

Drum-Mount Suction Kit

407018A

EN



Important Safety Instructions

Read all warnings and instructions in the TFG100
FDA Air-Operated Diaphragm Pump
manual. Save all instructions.

Kit 262828

Ref. Description

Ref.	Description	Qty.
1	ELBOW, reducer	1
2	TUBE, suction, drum length	1
3	BRACKET, mounting	1
4	ADAPTER, bung	1
5	WASHER, plain	4
6	SCREW, cap, hex head	4
7	NUT, hex, flange head	4
8	CLAMP, sanitary, 1.5 in.	1
9	GASKET, sanitary, 2 in., EPDM	1
10	GASKET, sanitary, 1.5 in., Buna-N	1
11	TRICLAMP, 2 in.	1

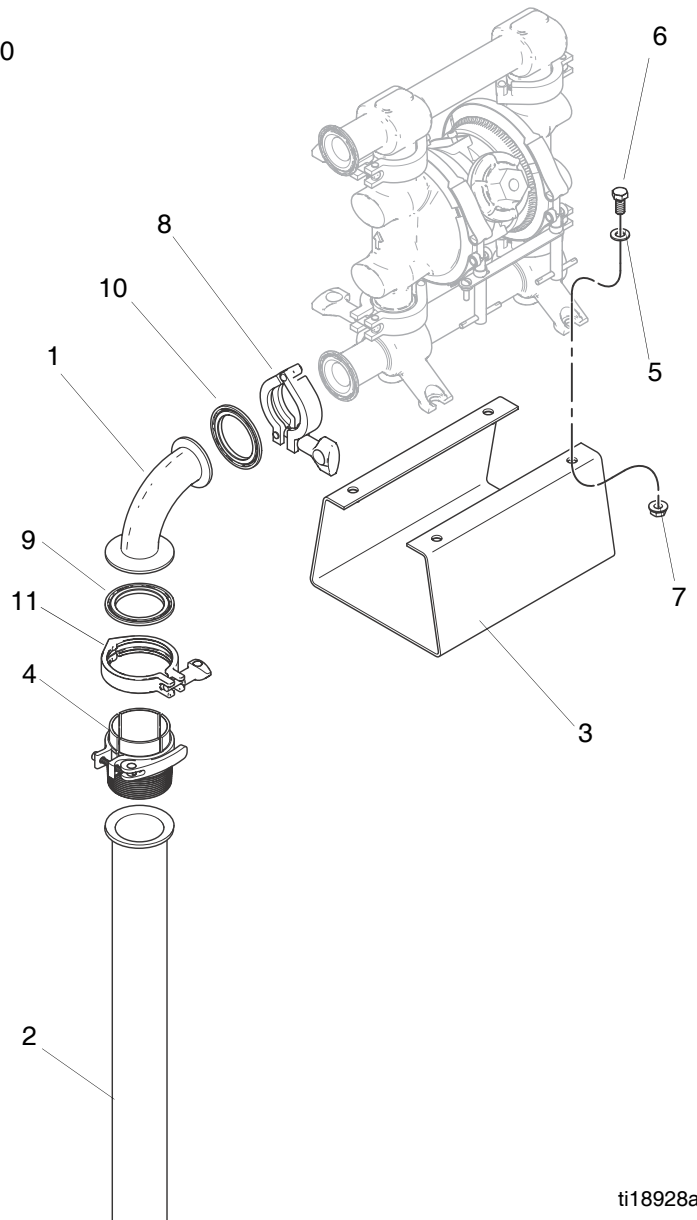

ti18928a

See reverse for installation instructions.

